

LED Troffer Installation Manual

Product Series: 2' x 2' / 2' x 4' LED Troffer

Rated Power: 32W/50W

Input Voltage: 100-277V, 50/60Hz



WARNING:

1. TO AVOID THE POSSIBILITY OF ELECTRICAL SHOCK, TURN OFF POWER SUPPLY BEFORE INSTALLATION OR REMOVAL.
2. FOLLOW NEC OR YOUR LOCAL ELECTRICAL CODE.

THIS PRODUCT MUST BE INSTALLED IN ACCORDANCE WITH THE APPLICABLE INSTALLATION CODE BY A PERSON FAMILIAR WITH THE CONSTRUCTION AND OPERATION OF THE PRODUCT AND THE HAZARDS INVOLVED.

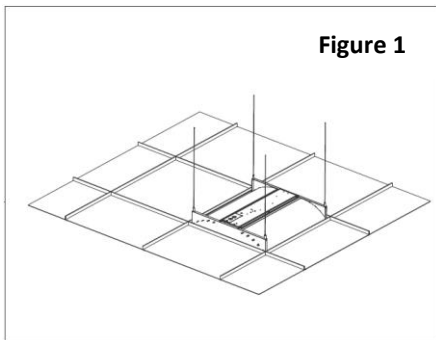

Figure 1

1. Install the luminaire into the reserved space in the ceiling. Attach the luminaire by the steel hook/safety cable.

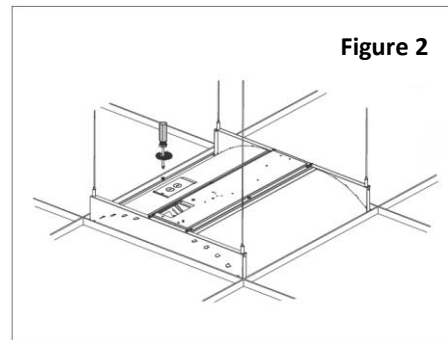

Figure 2

2. Remove electrical enclosure cover, and remove knockout for AC line input wires.

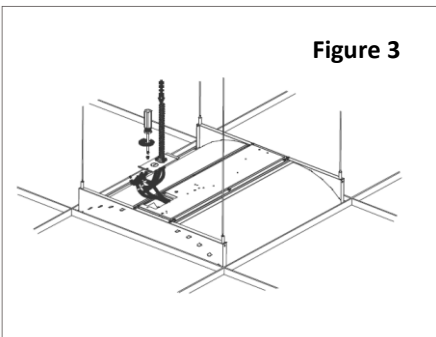

Figure 3

3. Install listed conduit in the knockout holes for wire protection. Make the following Electrical Connections (Figure 5):

Connect the black lead wire from the fixture to the black wire from the power supply, and the white wire from the fixture to the white wire from the power supply; and the green lead wire to the green ground lead.

If 0/1-10V Dimming is used, connect the violet lead wire to the supply positive dimming lead wire; the gray lead wire to the supply negative dimming lead wire.

If dimming is not being used, please ensure to cap off the gray lead wire.

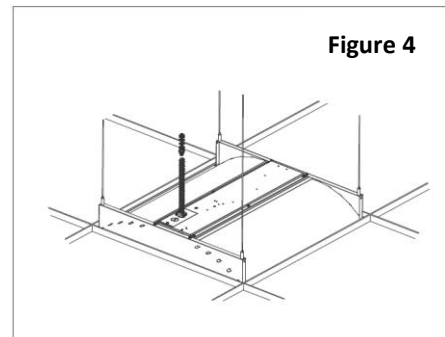

Figure 4

4. Push all lead wires into the electrical enclosure. Reattach electrical enclosure cover; make sure no wires are pinched.

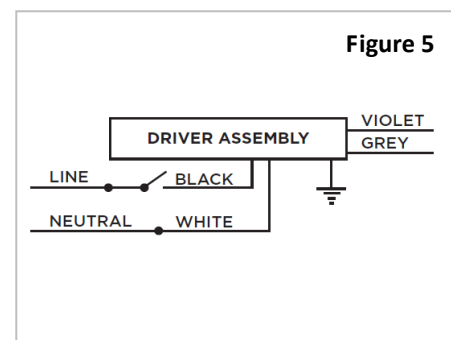

Figure 5

For more information, please visit www.forestlighting.com or email to customerservice@forestlighting.com